

| REV | REVISION | BY | ECN | DATE |
|-----|----------|----|-----|------|
|     |          |    |     |      |

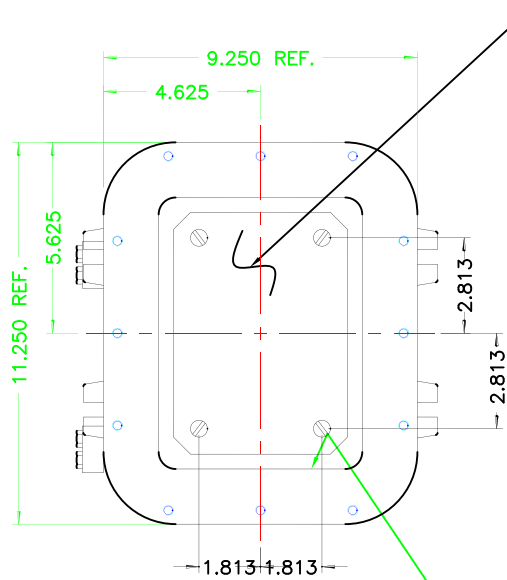

OPTIONAL MTG. PAN

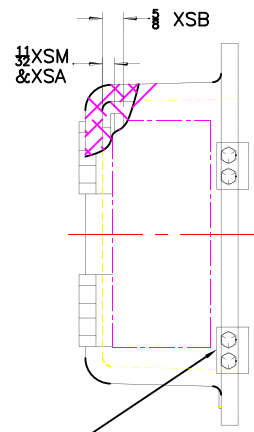
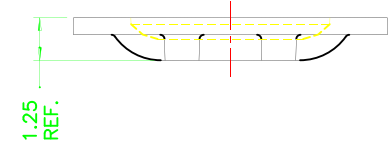
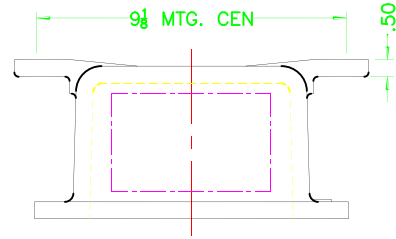
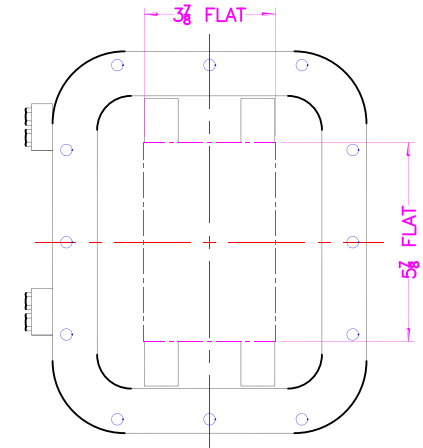
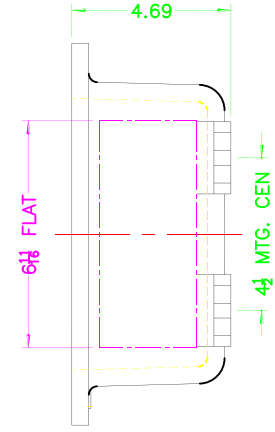

OPTIONAL XHB-2 HINGES

EXISTING GRD. SCREW

### XCE 0608 COVER

**NOTES:**

COVER DRILLING ALLOWABLE IN XCE ONLY

1. MINIMUM SPACING FROM CENTER OF OPERATOR TO NEAREST FLAT IS 1 1/8.
2. MINIMUM SPACING BETWEEN 3/4-14 NPSM OPERATOR CENTERS IS 2 1/2 FOR THIS ENCLOSURE.
3. MAXIMUM NUMBER OF OPERATORS IS 2.
4. DIMENSION FROM CENTER LINES OF COVER FOR OPERATORS.
5. DIMENSION FROM CENTER LINE AND BACK OF MTG. LUG FOR CONDUIT.
6. FOR MTG. ENCLOSURE USE 3/8 BOLT.

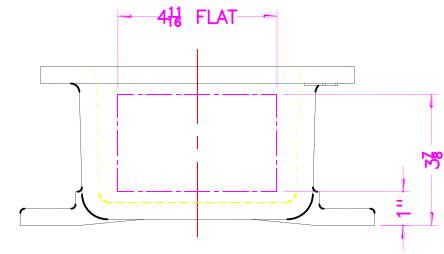

|  |  |                 |                 |  |                   |
|--|--|-----------------|-----------------|--|-------------------|
| DO NOT SCALE DRAWING<br>UNLESS OTHERWISE SPECIFIED DIMENSIONS ARE IN INCHES.<br>CAST TOLERANCES ON DIMENSIONS NOT OTHERWISE SPECIFIED:<br>1/8" STOCK<br>FILET OR CORNER RADI 1/8"<br>DRAFT 1 1/2"<br>FRAC ± 1/16"<br>ANGLES ± 1°<br>MACHINE TOLERANCES ON DIMENSIONS NOT OTHERWISE SPECIFIED:<br>√ = 125<br>FILET RADIUS .03" .300 ± .010"<br>EDGE BREAK .005"-.015" R. or 45°<br>ANGLES ± 0°-30°<br>GAGING FOR THREADED HOLES NOT OTHERWISE SPECIFIED:<br>NPT E-21-2.6<br>NPSM E-24-1.0 |  |                 |                 | TITLE<br>MODIFIED XCE/XJF 060804 ENCLOSURE FOR |                   |
| NOTICE TO PERSONS RECEIVING THIS DRAWING:<br>ADALET-PLM CLAIMS PROPRIETARY RIGHTS IN THE MATERIAL DISCLOSED HEREON. THIS DRAWING IS ISSUED IN CONFIDENCE FOR ENGINEERING INFORMATION ONLY AND MAY NOT BE REPRODUCED OR USED TO MANUFACTURE WITHOUT SHOWN HEREON WITHOUT DIRECT WRITTEN PERMISSION FROM ADALET-PLM TO THE USER.   |  | DRAWN BY<br>DDH | DATE<br>4-20-01 | ENG APPROVAL                                   | PLOT SCALE<br>1=3 |
| FINISH<br>TUMBLAST   |  | MFG APPROVAL    | DWG SIZE<br>C   | SHT<br>10F1                                    |                   |
| CAT NO<br>XCE/XJF 060804   |  | REV             |                 | DATE   |                   |