

| REV | REVISION | BY | ECN | DATE |
|-----|----------|----|-----|------|
| | | | | |

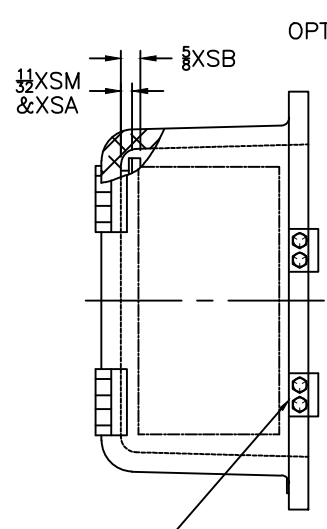

OPTIONAL MTG. PAN

OPTIONAL XHB-2 HINGES

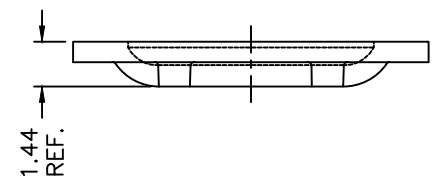
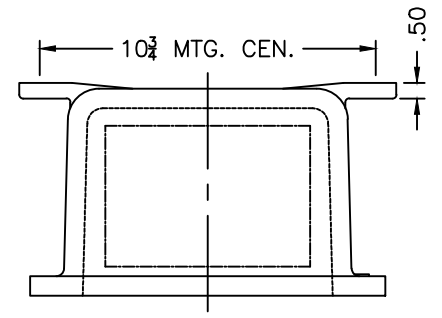
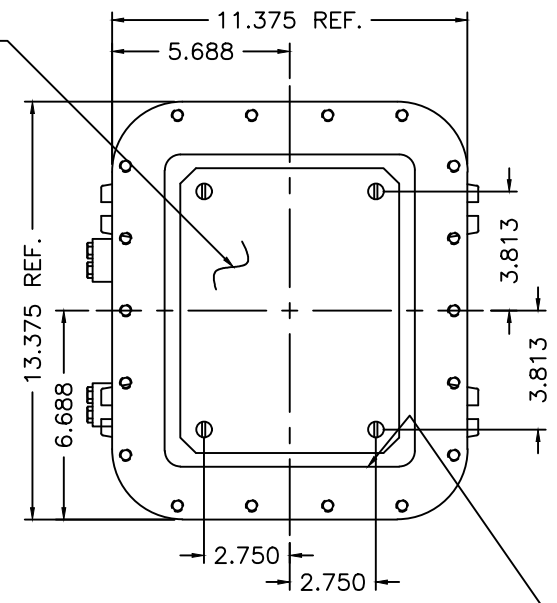

EXISTING GRD. SCREW

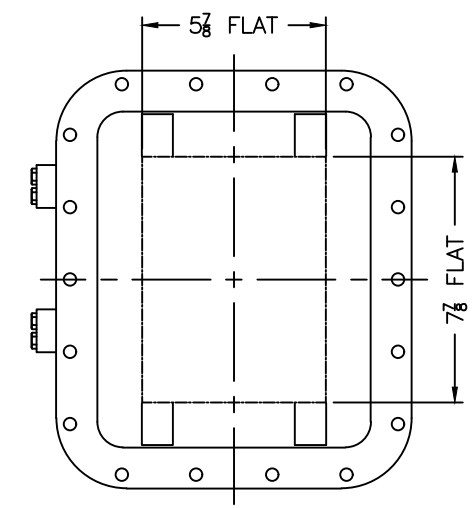
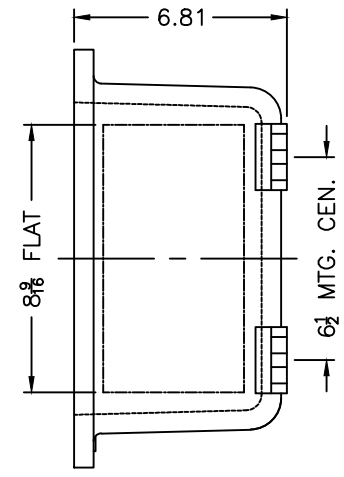

XCE 0810 COVER

NOTES:

COVER DRILLING ALLOWABLE IN XCE ONLY

1. MINIMUM SPACING FROM CENTER OF OPERATOR TO NEAREST FLAT IS 1 1/8.
2. MINIMUM SPACING BETWEEN 3/4-14 NPSM OPERATOR CENTERS IS 2 1/2 FOR THIS ENCLOSURE.
3. MAXIMUM NUMBER OF OPERATORS IS 6.
4. DIMENSION FROM CENTER LINES OF COVER FOR OPERATORS.
5. DIMENSION FROM CENTER LINE AND BACK OF MTG. LUG FOR CONDUIT.
6. FOR MTG. ENCLOSURE USE 3/8 BOLT.

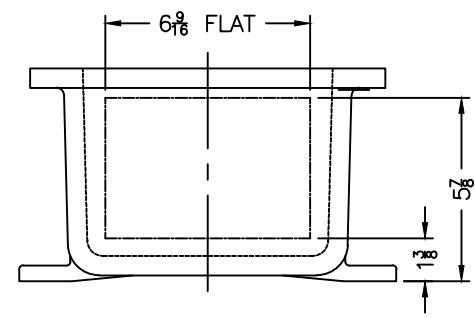

| | | | |
|---|--|--|--|
| DO NOT SCALE DRAWING UNLESS OTHERWISE SPECIFIED DIMENSIONS ARE IN INCHES. | | TITLE MODIFIED XCE/XJF 081006 ENCLOSURE FOR | |
| CAST TOLERANCES ON DIMENSIONS NOT OTHERWISE SPECIFIED: √ = 1/8" STOCK FILLET OR CORNER RADI 1/8" DRAFT 1 1/2" FRAC ± 1/16" ANGLES ± 1° | | DRAWN BY DDH DATE 6-13-01 | |
| MACHINE TOLERANCES ON DIMENSIONS NOT OTHERWISE SPECIFIED: XX ± .03" FILLET RADI .03" EDGE BREAK .005"-.015" R. or 45° ANGLES ± 0°-30° | | ENG APPROVAL PLOT SCALE 1=4 | |
| GAGING FOR THREADED HOLES NOT OTHERWISE SPECIFIED: NPT E-21-2.6 NPSM E-24-1.0 | | MFG APPROVAL DWG SIZE C | |
| FINISH TUMBLAST | | DWG NO | |
| CAT NO XCE/XJF 081006 | | SHT 10F1 REV | |